

DG-4000A
(water-cooled system type)

**INDUCTION ALUMINIUM FOIL
SEALER**

Operation Manual

(Please read this manual carefully before operation)

I、Summary

Compound material induction of sealing technology is world-widely regarded as an advanced way of sealing on packing. It is Increasingly adopted to seal and pack products in high quality, such as: medicines、 foods、 cosmetics、 pesticides、 chemical products and other bottled products. Continuum aluminum foil sealers of model DG-4000A are latest updated technology of induction and heat control. We also adopt advanced high frequency switch power supply technology , PLL technology and digital technology. We have made great progress on mini-type, high stability and high effect.

II、Theory

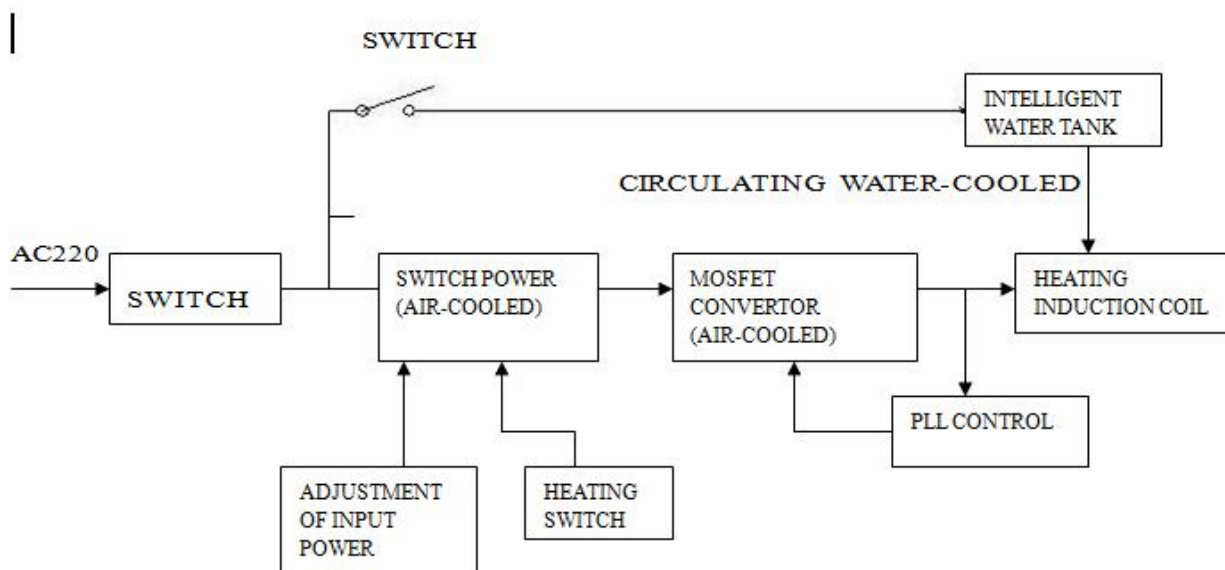

Working principle flow chart

The working theory is based on the high frequency of magnetic field, which makes the foils engender immense whirlpool and be heated quickly. The agglutinate membranes under the foils are melted, which makes the foils conglutinated to the bottles' to achieve the goal of airproof sealing rapidly and untouchably. The main power units are induction utensil of heating are placed above a big radiator and they are cooled forcedly by wind. The heat inductor adopts cycle water adjustor.

III、 Main parameter:

1. Power supply: $\sim 220V \pm 10\%$, 50/60Hz
2. Current supply: static state $\leq 8A$, dynamic state $\leq 17A$
3. Output power: (adjustable), 4KWmax
4. Output wave: sine wave, 60~80KHz
5. Cooled water Flux : 2.5 ~4 (L/min) Pump control
6. Jacket PSI: IP21
7. Cooling Water: pure water (distilled water) $> 1 \sim 55^{\circ}C$
8. Induction head's sealing diameters:

W40: Trough width 40mm, 15mm<sealing diameter<55 mm(the bottle less than 35mm be sealed inside of the through, and the others to be sealed outside.)

W55: Trough width 55mm, 30mm<sealing diameter<70 mm (the bottle less than 50mm be sealed inside of the trough, and the others to be sealed outside).

W100: Flat base, 60mm<sealing diameter<140mm

Nonstandard model: Customized.

IV、 Schematic Diagram of control board

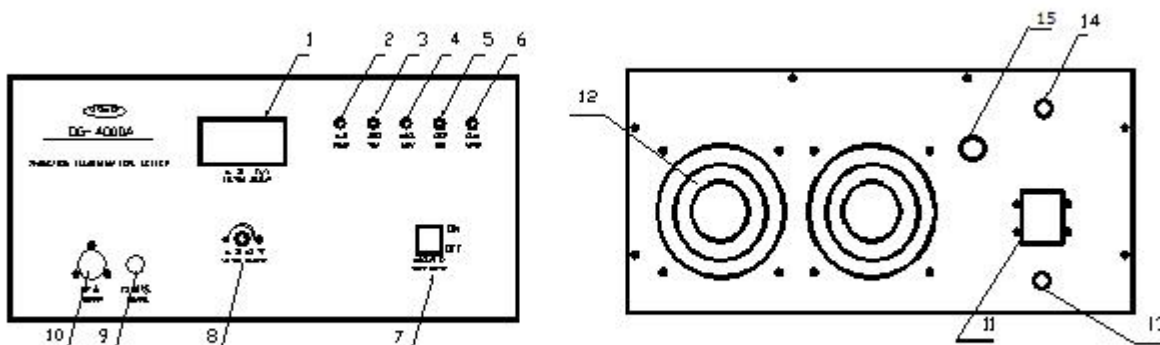

- 1.Output voltage meter 2 Power Indicator 3. Detecting indicator: 4.Heating indicator
 5.cooling indicator 6.Water-lacked indicator 7.Heating Switch. 8.voltage adjustor
 9.control liner(connect to intelligent water tank) 10.output (connect to heat head) 11.power on/off 12. dustproof ring
 13.power line 14. fuse for water tank 15.Water tank test botton

V、 Schematic Diagram of heating sensor

W40,W55 heating sensor

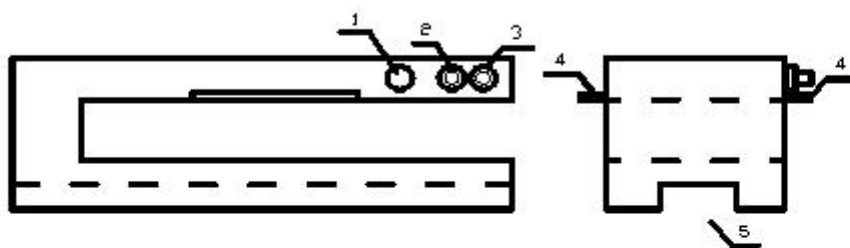

W100 heating sensor

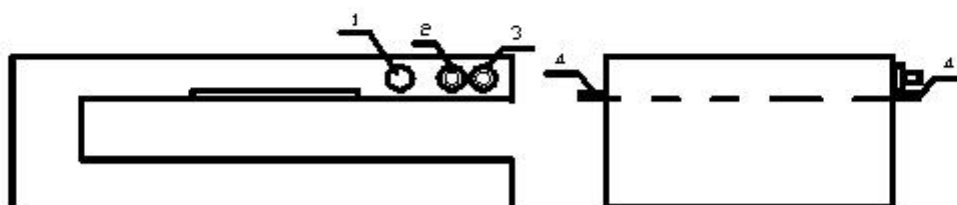

1. Power output port (connect to the main machine)
 2. Water exit (hose connect to intelligent water tank)
 3. Water entrance (hose connect to intelligent water tank)
 4. Fixing screw
 5. Trough

VI Attention matters for installation & usage:

Installation diagram

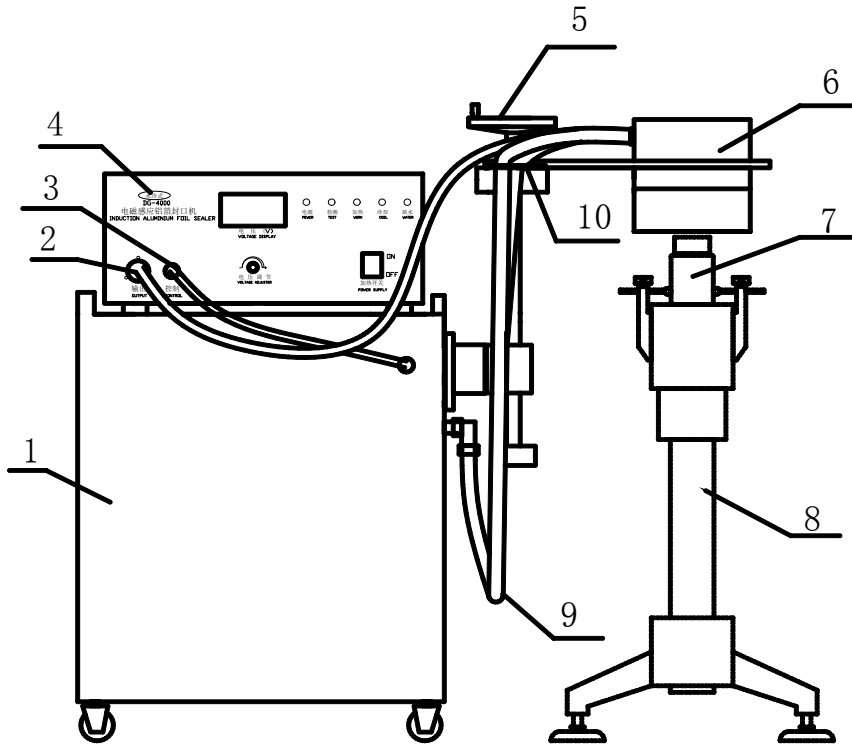

- 1.water tank 2. output line 3. control line of water tank 4. host 5. lifting
Frame 6. inductor 7 .bottle 8. conveyor 9 Water pipe 10 The pipe bending device

Diagram of water tank

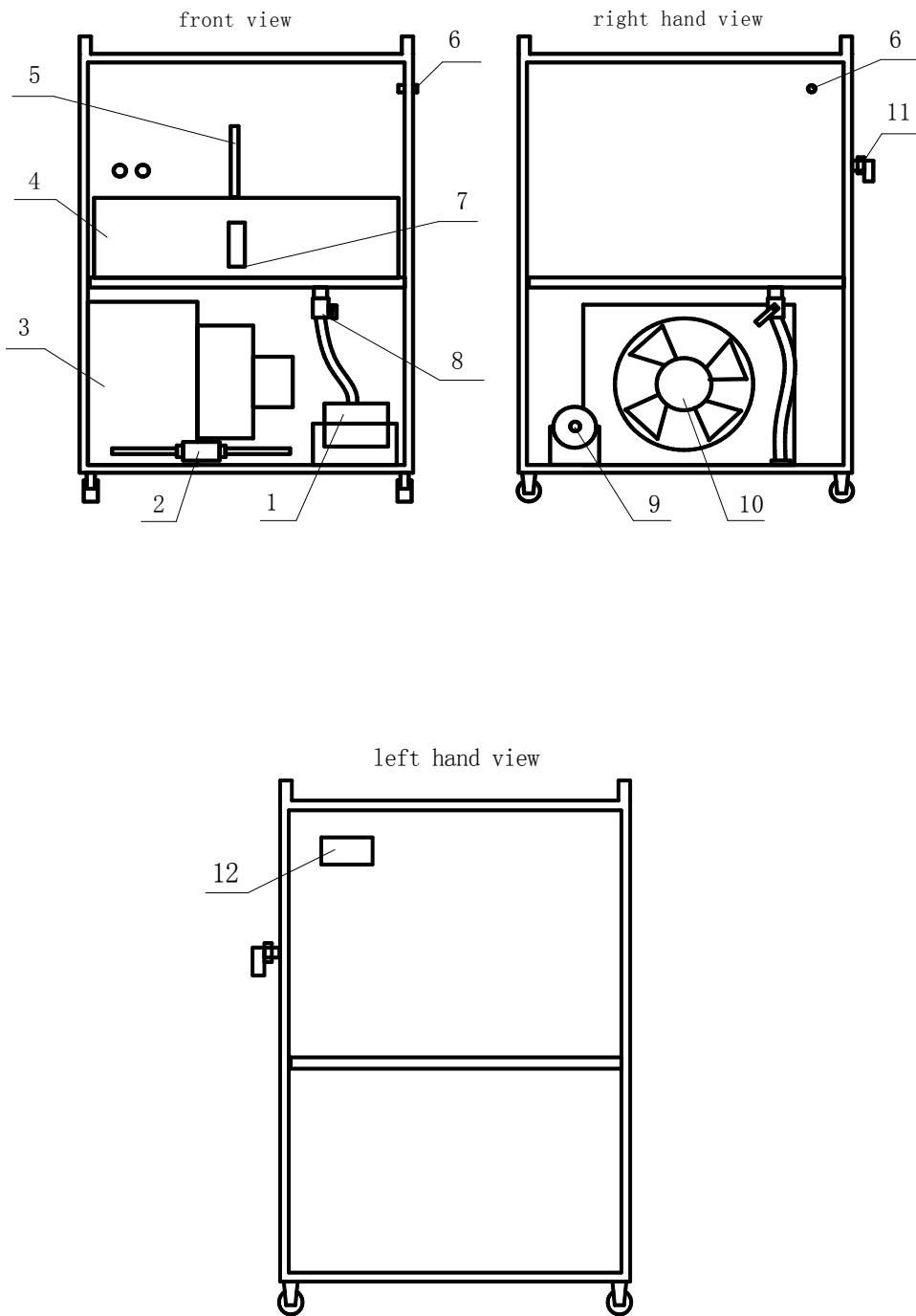
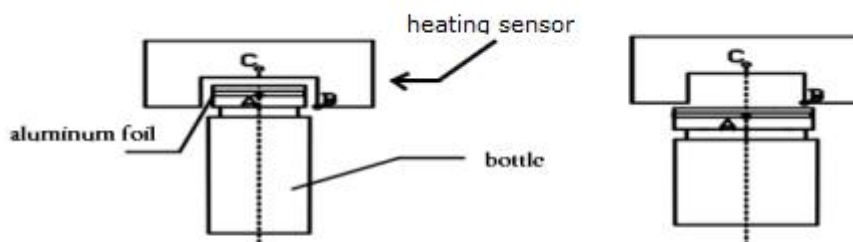

Figure 5

1water pump 2water pressure inductor 3condenser 4through 5water-return pipe 6、
water pipe 7. water level scale 8. drain valve 9、air vent screw of water pump 10、
air fan 11. water pipe 12、 detector of cooling liquid

DG-4000A water-cooled Induction Aluminum Foil Sealer

1. The sectional area between the power supply circuit wire and the grounded circuit wires should be larger than 2.5mm^2 . It's necessary to equip with voltage regulator to guarantee the machine working in normal when the local power supply is unstable. The three-hole receptacle must be connected to ground.
2. The machine must be reposefully installed in a dry, clean, no dust, nor corrosive gas, ventilation environment and far away from radiations and heat sources.
3. Please pour the water following the water level line when you open the intelligent tank, which is connecting to main machine and working until its main machine heating up. Please inspect the water circle situation carefully now, the operator should stop immediately if there is water leak or any abnormal phenomenon appeared.
4. Please do exhaust the air in the pump of the water tank before first time using, or the pump could not work normally. Please these steps: fill the trough in the tank with water(power off),loosen the venting screw(PIC.5)of the pump, when the water comes out from the screw hole then fasten the screw. When the machine goes in to normal running status, there is no necessary to do these again.
5. There are different requirements for the caps with different diameters while passing the heating sensor, listed as below:
 - a. Model of W40&W55
Regarding to the bottles which caps could pass through the trough, please adjust heating sensor's height according to the height of bottle. The centre point of cap A(side of aluminum foil) should behgher than heating induct point B(7mm upon B is best), the cap center A should be aim at heat inductor center C.(figure 6).For the caps which are too large to pass through the trough should be sealed when locating at the right under eath of the trough,but please as sureaim at the center line of A and B.



A center point of aluminium foil B heating sensor's groove C heating sensor's center

b. Model W100

When the diameter of aluminum foil is between 60mm and 100mm, please pass the bottle through the bottom side of heating sensor follow figure A; while the range is 100mm~140mm, please figure B.

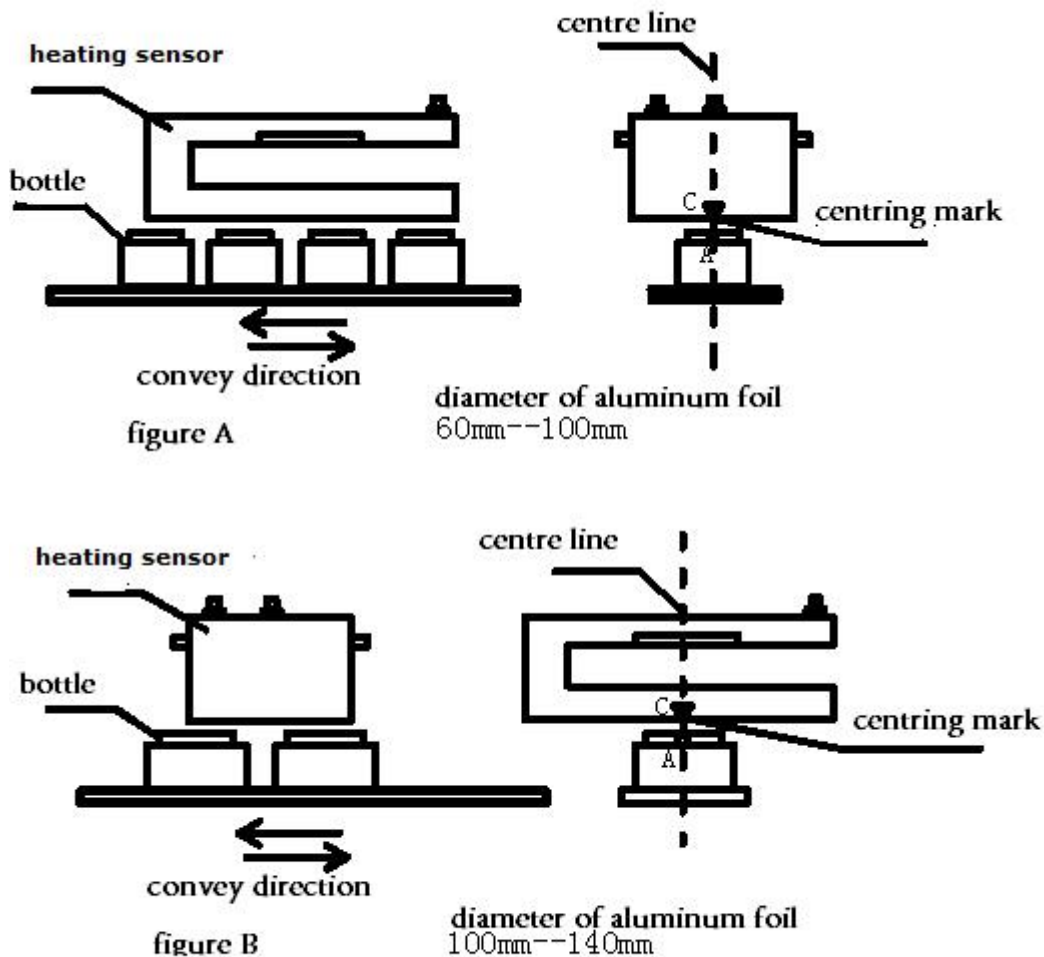

figure 7

6. Operating steps: First, install the main machine, inductor, water tank, lifting frame according to the installation diagram (figure 4), install the tank follow instruction 3rd and 4th. Then put the bottles whose caps screwed tightly and loaded with aluminum foil already on the conveyor belt. Adjust the lifting frame to make the bottles could pass through the bottom side of the inductor, meanwhile adjust the centering device of the conveyor belt and the inductor to make the bottles' center line (the centre point of aluminum foil A, figure 5&6) aim at the heat inductor's center line (point C, figure 6&7). When centering adjustment finished, indicator on the main board shows yellow (this means the power and circuit are both at normal status). Press the start button (9th button in figure 2), then the working indicator shows green light, this means the machine is in running status meanwhile the intelligent tank starts to work. Adjust the output voltage (its value accords to the actual condition) and the speed of the conveyor (accords to the actual condition). When the bottles pass through the inductor head, they were sealed automatically well. In order to get

the best performance, the operator should find out the best technology parameters(voltage/height/speed) through a sealing technology test, and record the parameters. Please keep the irrelevant people away from the machine avoiding the parameters being modified. 30 seconds after heating stop, the intelligent tank will stop automatically.

7.Instruction for water-lack protective function:

The main machine will be alarm, the over-heat indicator be flashing and automatic stop heating, while the cooling system of intelligent tank was lack of water on heating process. After 5 seconds, if not solved, the intelligent tank will stop automatically, and meanwhile you should turn off the machine and check out. Turning off the heating switch to release the alarm.

8.Instruction for detector of the tank cooling liquid:(12th figure 5)it detects the flow and temperature of the cooling liquid in the tank in real time.

a. The displayed digits on the meter will glint and send a trouble signal to the host while the current flow is less than 1.5L/min(the normal flow is 3.1L/min±20%).If this trouble is not solved in 5 seconds or even setting-off,the host will alarm and stop running automatically.

b. The displayed digits on the meter will glint and send the overheating signal to the host while the temperature of the cooling water in the tank is higher than 60°C.If overheating keeps more than 5 seconds, the host will alarm and stop automatically.

9.Please keep the in-outlet of the host fan clean and ventilated because the machine produces heat while running.

10.The heating sensor is circulating cool by pure water pump, please remain the adequate water free flowing in circle.

11.The induction head to be power output part of the induction sealer which is setup to meeting with inside circuit, accordingly, please do not disassembly by curiously, otherwise, it might affect the work power output efficiency, even burnt the electric elements inside.

12.The inductor coil will generate large amount of current on working, which is forbid the operator the separate the induction head with main machine.

Otherwise, the electric elements are easily burnt to damage the sealer.

13.Do not seal the bottles with materials which easily to be fired or bombed!

VII、 Maintenance

1. main machine dustproof loop: we suggest clean the two dustproof loops behind main machine.(it is convenient to clean only off four screw cap in every dustproof, figure 2) or exchange new one.(it is subject to environment locale)

2. Intelligent water tank adopts pure water(distilled water),keep adequate volume of water in tank (check the water level, not lower than 4/5 height), prohibit any miscellaneous articles or objects drop into water. The water tank is equipped with a drainage valve, you should regularly change water when the cooled water is dirty with miscellaneous objects inside. Regularly to check the ventilation

blower and electric water pump to keep working in normal.

3. Please dry the tank first and add pure antifreeze into the tank(not mixed brand) when the environment temperature is subzero; while the environment temperature is higher than 0℃,please turn back to the pure water. Please do clean the tank and circulatory water channel, antifreeze instead of pure water could not be used for long term.

VIII、 troubleshooting:

Trouble	Cause	Solution
E01	The input voltage is too low	Ensure that the machine is used at rated voltage
E02	Water tank flow <1.5L Water level is too low Water temperature is too high	Drain the pump's air. Add water to above the water level. Drain the hot water of the water tank, and then add cold water.
E03	The power tube overheating	Improve the main chassis ventilation environment
E04	Overload	Appropriate increase the distance of the heating sensor from the bottle
E05	Heating sensor disengagement	Check the heating sensor connection
E06	Overcurrent or other faults	Please refer to items 3 and 5 above
One side of the bottle not well sealed	The centerline of the bottle is inconsistent with the centerline of the heating sensor	Adjust the Center Control system of the conveyor belt so that the centerline of the bottle is aligned with the centerline of the heated sensor head
Some bottles are not well sealed	The cap is not tightened, causing the aluminum foil inside the cap can not full contact with the bottle	1, try to make sure the aluminum foil inside the bottle cap full contact with the bottle
	The speed of the conveyor belt is too fast or the output voltage is too low , causing the sealing power is insufficient	2, appropriate to reduce the speed of the conveyor belt

P.S: There may be some changes to the machine structure and parameters ,based on the standard of material object. It's prohibitive to change the machine without the permission of the manufacture, or you will be fully responsible for any resulting consequences.